

IF IN DOUBT ASK

ISSUE	DATE	DRAWN	ECR No	CHECKED	APPROVED
1	11/01/2020	DR	NEW DWG	JS	AS

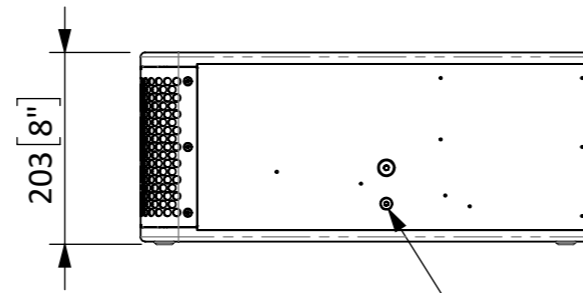

FIXING FOR YOKE BRACKET
(SOLD SEPARATELY)

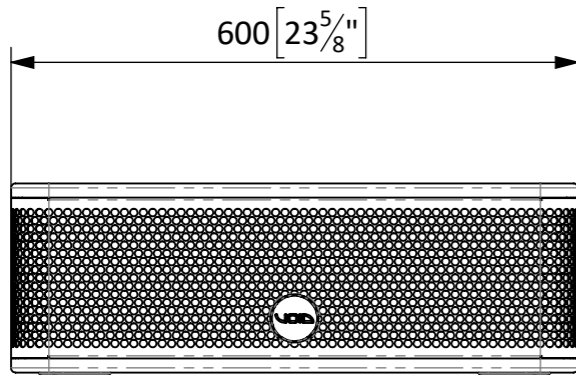
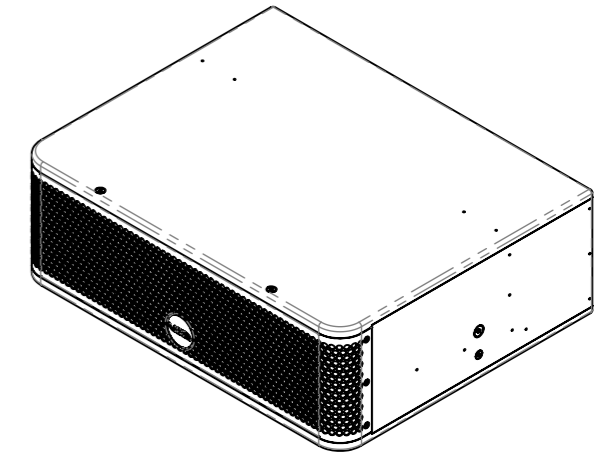
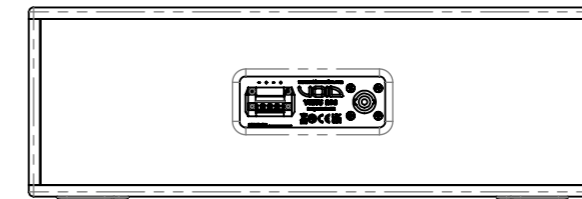

FIXING FOR TYPE 75 PLATE
(SOLD SEPARATELY)

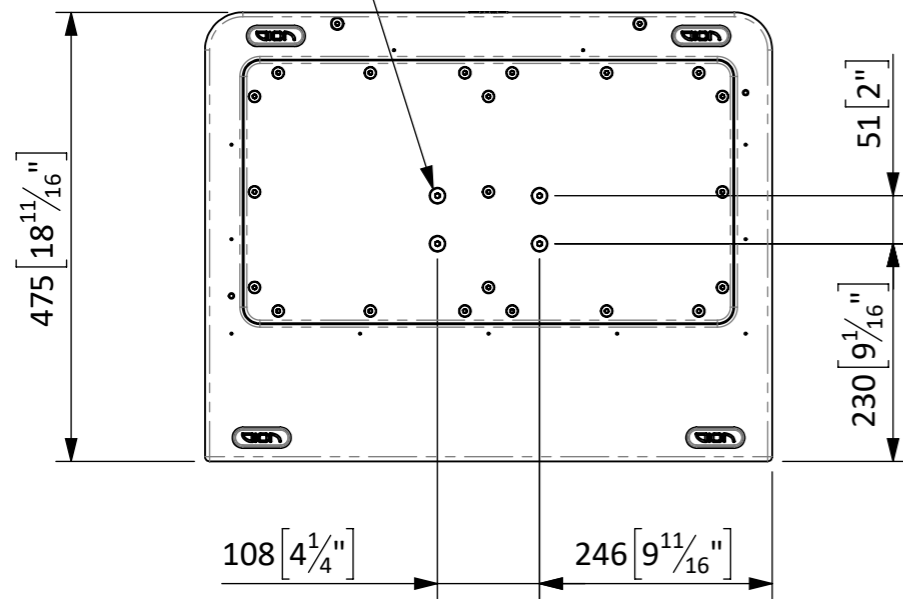

DIMENSIONS IN MILLIMETRES			
FABRICATION UNLESS OTHERWISE STATED		MACHINING UNLESS OTHERWISE STATED	
UP TO 300mm	+/-0.2mm	0, mm	+/- 0.5 mm
300mm-500mm	+/-0.5mm	0,0 mm	+/- 0.2 mm
500mm - 1m	+/-1.0mm	0,00mm	+/- 0.1mm
1m - 5m	+/-2.0mm	0,000mm	+/- 0.01mm
ANGULAR	±1°	ANGULAR	±0.5°

SURFACE TEXTURE VALUES IN MICROMETRES (µm) TO BS1134-PT2.
ALL MACHINED SURFACES TO BE ✓ ALL SCREW THREADS TO BS3643 PT.2.

TITLE: VENU 208 ASSEMBLY		DRAWING No. SP10116-001	
PROJECT: VENU 208		SAP No. IT3100	
MATERIAL: AS ABOVE		EST. WEIGHT: (Kg) 13.24	
FINISH: PAINT (WARNEX)		COLOUR: BLACK	TEXTURE:
THIRD ANGLE PROJECTION TO BS 8888	SCALE: 1:8	SHT 1 OF 1 SHTS	SHEET: A3



REPRODUCTION OF ANY PART OF THIS DOCUMENT IS FORBIDDEN WITHOUT
PRIOR PERMISSION FROM VOID ACOUSTICS RESEARCH LTD.
Registered in England & Wales No. 07533536
© DESIGN COPYRIGHT RESERVED.
CONFIDENTIAL AND PROPRIETARY INFORMATION OF VOID ACOUSTICS RESEARCH LTD.