

IF IN DOUBT ASK

ISSUE	DATE	DRAWN	ECR No	CHECKED	APPROVED
3	30/09/2019	DR			

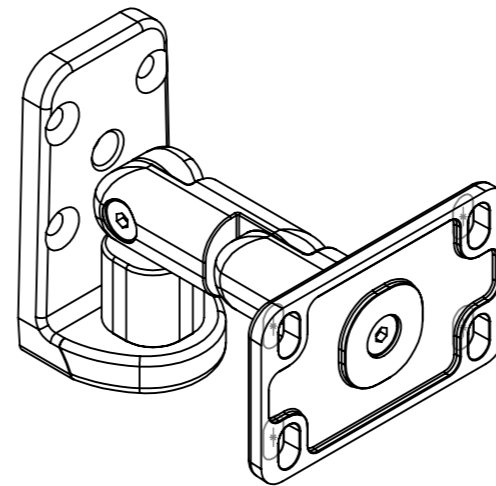
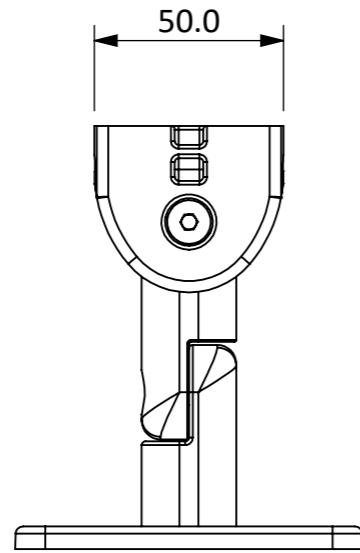
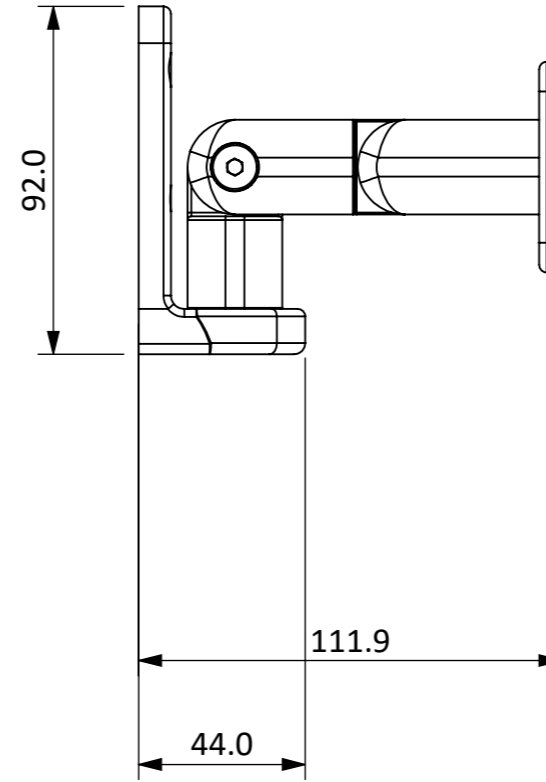
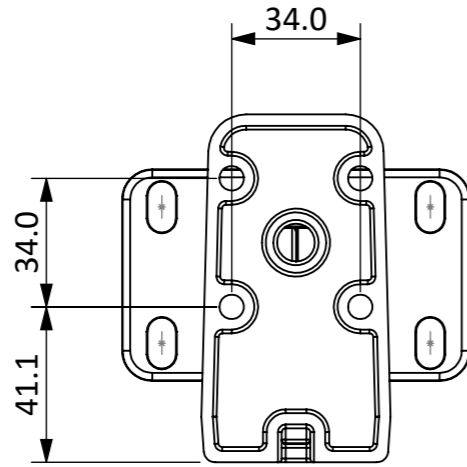

DIMENSIONS IN MILLIMETRES			
FABRICATION		MACHINING	
<small>UNLESS OTHERWISE STATED</small>			
UP TO 300mm	+/-0.2mm	0, mm	+/- 0.5 mm BREAK EDGE
300mm-500mm	+/-0.5mm	0,0 mm	+/- 0.2 mm 0.05 - 0.15mm
500mm - 1m	+/-1.0mm	0,00mm	+/- 0.1mm FILLET RADIS
1m - 5m	+/-2.0mm	0,000mm	+/- 0.01mm 0.1 - 0.3mm
ANGULAR	±1°	ANGULAR	±0,5°

SURFACE TEXTURE VALUES IN MICROMETRES (µm) TO BS1134-PT2.  
ALL MACHINED SURFACES TO BE ✓ ALL SCREW THREADS TO BS3643 PT.2.

TITLE: <b>T51 WALL BRACKET</b>		DRAWING No. <b>BR10141-102</b>	
PROJECT: <b>CYCLONE 55</b>		SAP No.	
MATERIAL: <b>AS ABOVE</b>		EST. WEIGHT: (Kg) <b>0.22</b>	
FINISH: <b>POWDER COAT MATT (HMG)</b>		COLOUR: <b>WHITE</b>	TEXTURE: <b>FINE</b>
THIRD ANGLE PROJECTION TO BS 8888	SCALE: <b>1:2</b>	SHT 1 OF 1 SHTS	SHEET: <b>A3</b>



REPRODUCTION OF ANY PART OF THIS DOCUMENT IS FORBIDDEN WITHOUT  
PRIOR PERMISSION FROM VOID ACOUSTICS RESEARCH LTD.  
Registered in England & Wales No. 07533536  
© DESIGN COPYRIGHT RESERVED.  
CONFIDENTIAL AND PROPRIETARY INFORMATION OF VOID ACOUSTICS RESEARCH LTD.