

IF IN DOUBT ASK

ISSUE	DATE	DRAWN	ECR No	CHECKED	APPROVED
1	14/10/2020	JB		DR	AS

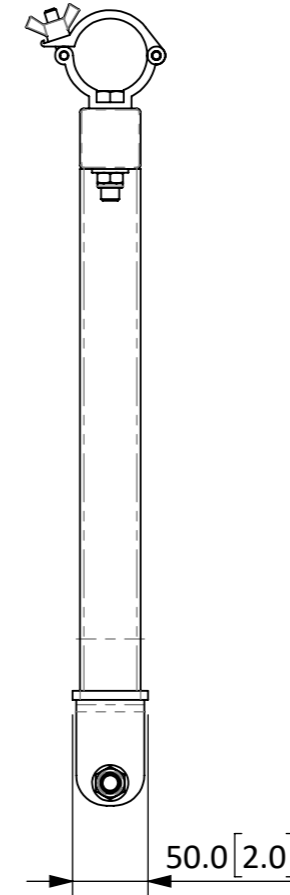
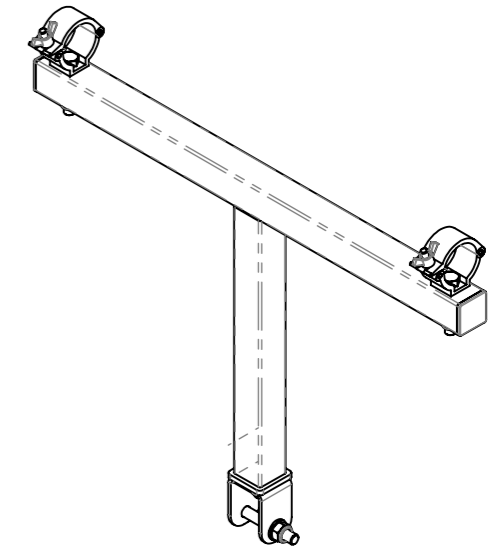
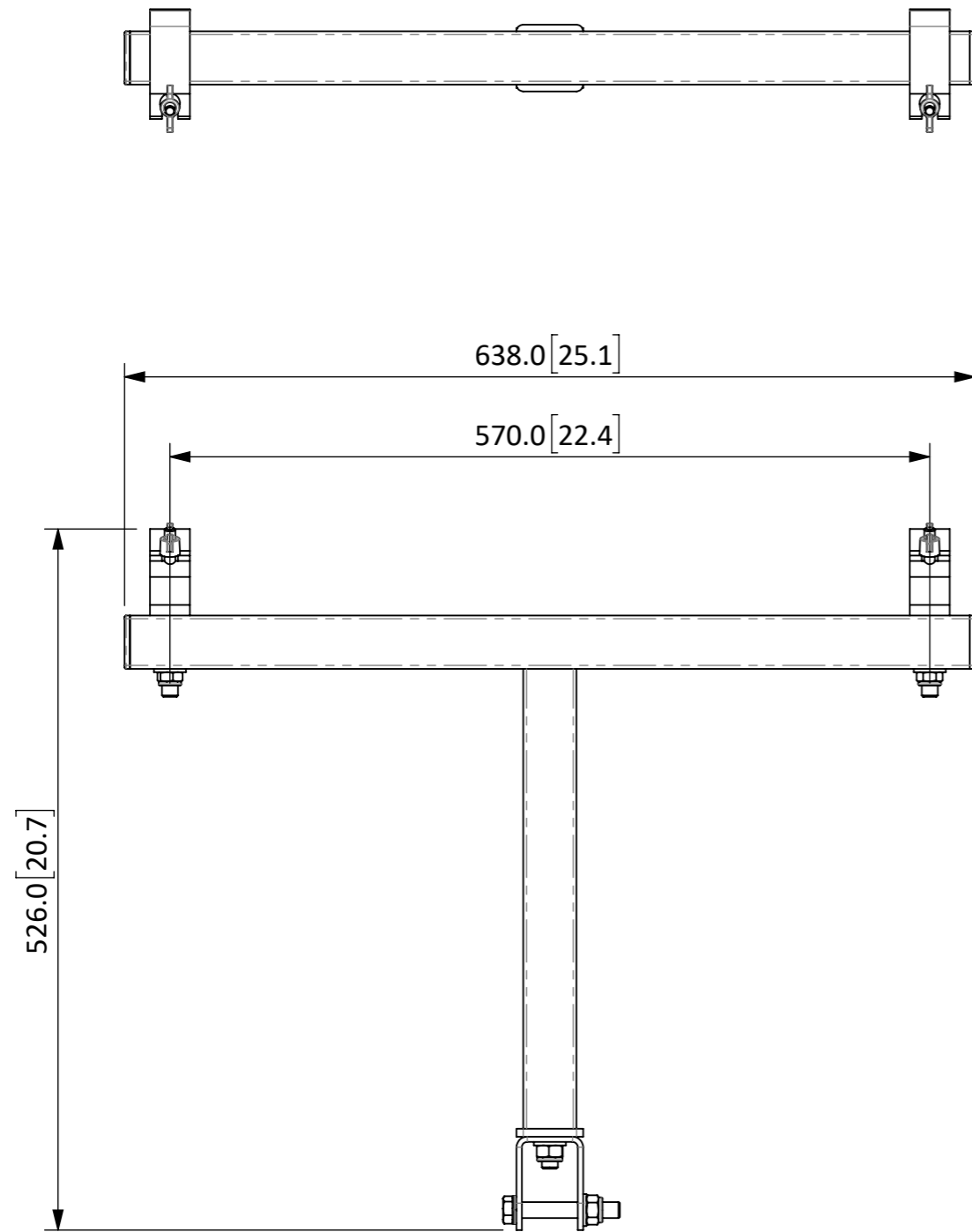

DIMENSIONS IN MILLIMETRES			
FABRICATION UNLESS OTHERWISE STATED		MACHINING UNLESS OTHERWISE STATED	
UP TO 300mm	+/-0.2mm	0, mm	+/- 0.5 mm
300mm-500mm	+/-0.5mm	0,0 mm	+/- 0.2 mm
500mm - 1m	+/-1.0mm	0,00mm	+/- 0.1mm
1m - 5m	+/-2.0mm	0,000mm	+/- 0.01mm
ANGULAR	±1°	ANGULAR	±0,5°

TITLE: <b>TU TRUSS BRACKET</b>		DRAWING No. <b>BR10420-002</b>	
PROJECT: <b>BRACKETS</b>		SAP No. <b>IT1081</b>	
MATERIAL: <b>AS ABOVE</b>		EST. WEIGHT: (Kg) <b>4015.73</b>	
FINISH:		COLOUR: <b>WHITE</b>	TEXTURE:
THIRD ANGLE PROJECTION TO BS 8888	SCALE: <b>1:5</b>	SHT 1 OF 1 SHTS	SHEET: <b>A3</b>



REPRODUCTION OF ANY PART OF THIS DOCUMENT IS FORBIDDEN WITHOUT  
PRIOR PERMISSION FROM VOID ACOUSTICS RESEARCH LTD.  
Registered in England & Wales No. 07533536  
© DESIGN COPYRIGHT RESERVED.  
CONFIDENTIAL AND PROPRIETARY INFORMATION OF VOID ACOUSTICS RESEARCH LTD.